

DRINK MIXER #54
Electric shaker



Internationally patented models

THE IDEAL DRINK MIXER...

The drink mixer #54 is the ideal equipment to make milk shakes, cappuccino cream, smoothies, ice cream drinks...

This drink mixer is a long lasting equipment for **professional users** with:

- A **speed variation** from 8000 to 16000rpm
- A heavy duty and **silent motor**
- Automatic motor activation with **bowl detection**

It is provided with:

- **2 bowls** (0.675L/24fl oz): 1 stainless steel bowl and 1 plastic bowl
- **3 removable agitators** (by simple screwing /unscrewing on the spindle):
 - » 1 universal spherical agitator for all beverages
 - » 1 rubber agitator for creamy beverages
 - » 1 winged deep agitator for frozen coffee

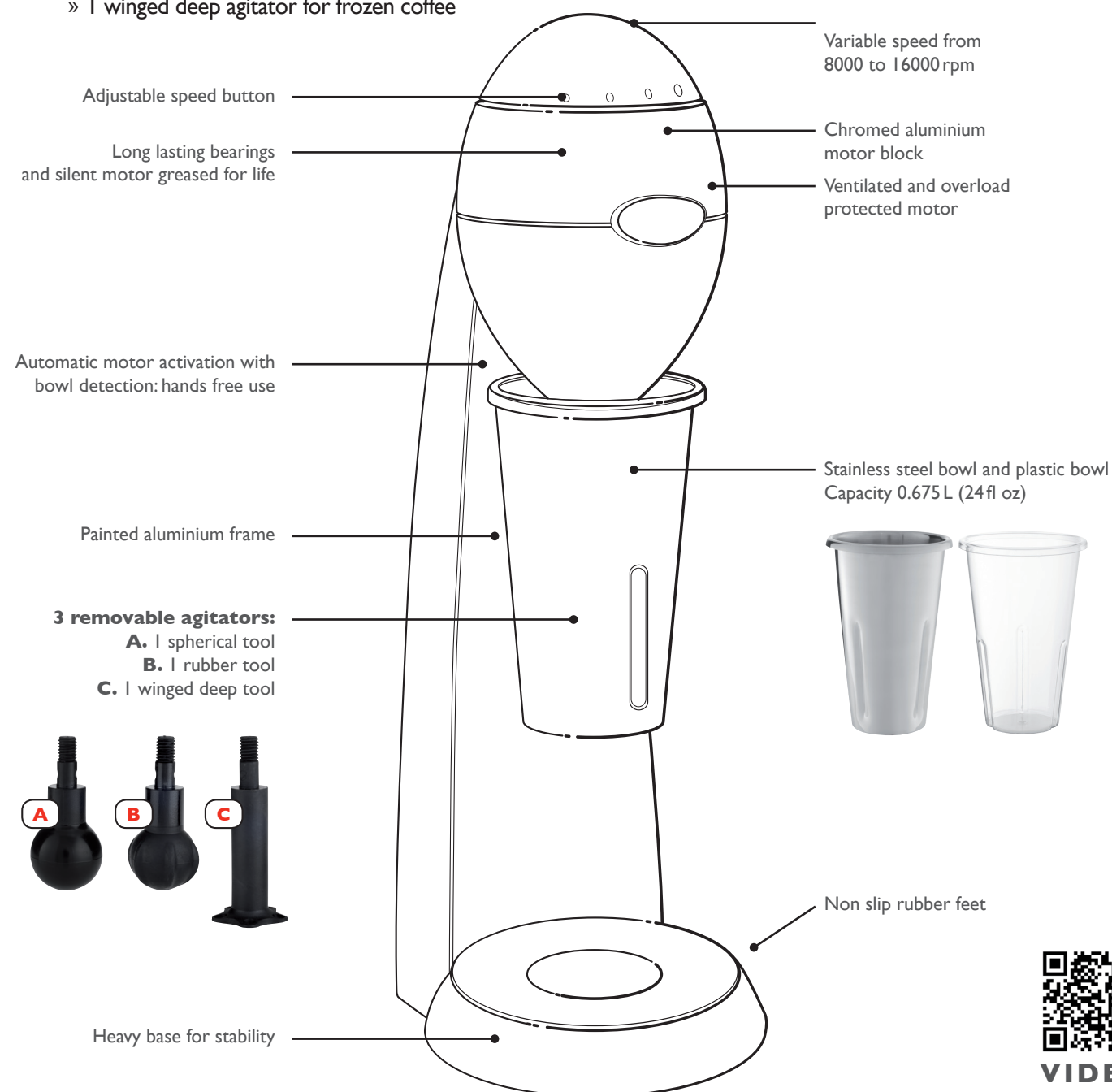

VIDEO

CHOOSE THE BLENDER SUITABLE FOR YOU

www.santos.fr



Thanks to the wide range of Santos blenders, you can make all sorts of drinks, cocktails and soups.

- #37: blender for both hot and cold beverages
- #62: brushless blender for smoothies and iced drinks
- #33: small blender for cocktails and drinks
- #54: drink mixer for milkshakes and ice cream drinks

TECHNICAL SPECIFICATIONS



Motor

Single phase: 100 - 120V - 50/60 Hz – 230 W
NSF, UL, CE, ROHS

220 - 240V - 50/60 Hz – 230 W
CE, NSF, ROHS

Variable speed: 8000 to 16000rpm (50/60 Hz)



Weight

Net: 6 Kg (13.5")
Shipping: 6.5 Kg (14.5")

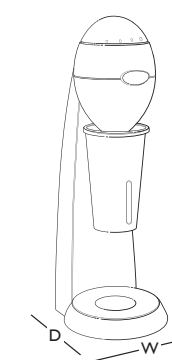

APPLIANCE
W: 182 mm (7.5")
D: 186 mm (7.5")
H: 530 mm (20")

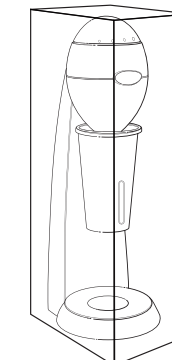

SHIPPING BOX
W: 215 mm (8.5")
D: 244 mm (9.6")
H: 600 mm (23.6")

SAFETY, STANDARDS, HYGIENE

In accordance with the following regulations

Machinery directive 2006 / 42 / EC
Electromagnetic compatibility 2014 / 30 / EU
"Low voltage" directive 2014 / 35 / EU
RoHS directive 2011 / 65 / EU
Regulation 1935 / 2004 / EC (contact with food)
Regulation 10 / 2011 / EU (Plastic in contact with food)

Harmonized European standards

EN ISO 12100 : 2010
EN 60204-1 + A1: 2009
EN 60335-2-64 :2004 Commercial electric kitchen machines

CE Marking, NSF (USA), UL (USA) et cUL (Canada)

Electrical safety

All mechanical parts are ground (earth) connected
All equipment is perfectly controlled after assembly (special electrical testing bay)
Overload safety.

Thermal safety

Motor protected by internal thermal detector and thermally disconnected from the body to protect user against heat

Acoustic safety

The universal motor is particularly silent

Hygiene

All removable parts can be put in a dishwasher or easily cleaned with hot soapy water (NSF approved)

PRODUCT: 2-YEAR WARRANTY

DRINK MIXER #54 ELECTRICAL SHAKER

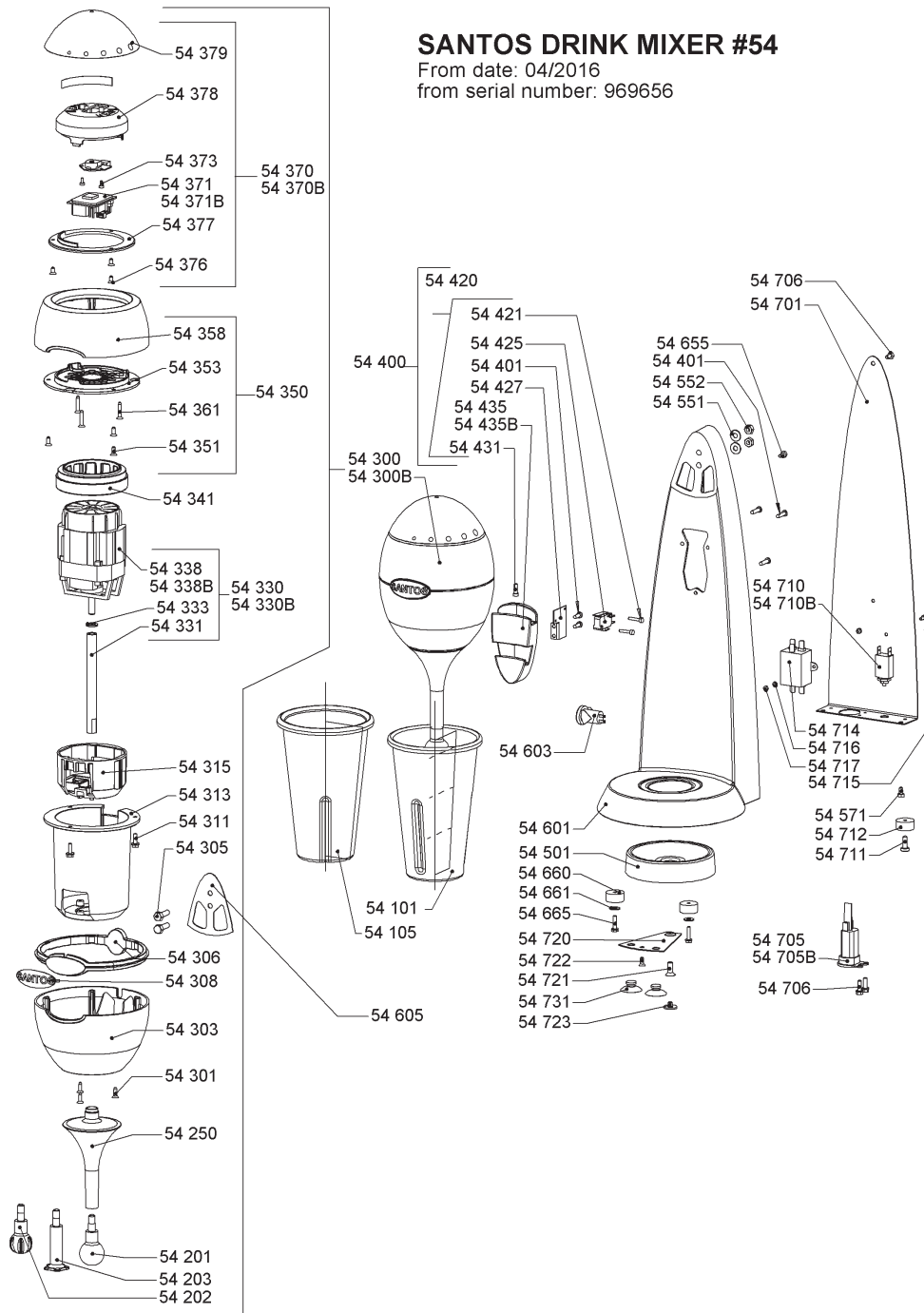

07/2019 - V7

SANTOS

140-150 Avenue Roger Salengro BP 80 067 – 69511 Vaulx-en-velin Cedex (Lyon) – FRANCE
 Tel. +33 4 72 37 35 29 – Fax. +33 4 78 26 58 21 – **Website:** www.santos.fr – **Email:** santos@santos.fr

Follow us on #SantosAddict social networks